

Model HP10SC-E/XL

Electric Scissor Pallet Truck

An electrical powered Pallet Truck for fast moving and lifting pallet.

- ▶ It prevents the unit from moving when the forks are raised to keep the safety of the operator.
- ▶ The design of the machine makes it suitable to function as scissor lift table / Pallet Truck.
- ▶ Truck automatically slows the descending speed when heavy goods loaded to prevent cargo damage.

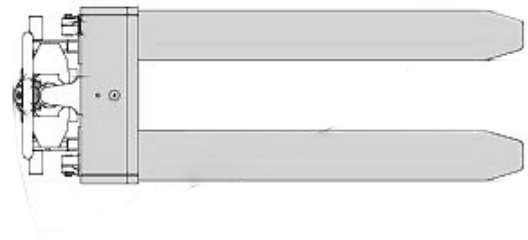
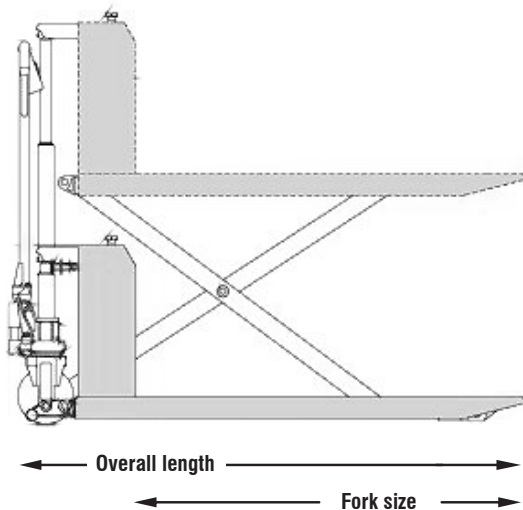

Model	Load capacity [kg.]	Fork size [mm.]	Min. / Max. height of Fork [mm.]	Overall length* [mm.]	Turning radius [mm.]	Weight** [kg.]
HP10SC-E/XL	1000	685 x 1245	85 / 800	1652	1480	181

